

Dalmaray Concrete Products Inc. Tank Model 600

Model 600 Septic, Holding, Sedimentation,
Pump, or Siphon

642 gal. septic
672 gal. holding

300 GPD WHEN USED AS A SEPTIC TANK
BASED ON A 3 YR SERVICE INTERVAL

DIMENSIONS:

LENGTH - 78"

WIDTH - 59"

HEIGHT - 60"

BELOW INLET - 47"

TANK WEIGHT - 4600 lb.

LID WEIGHT - 2400 lb.

MAX DEPTH OF BURY 108"

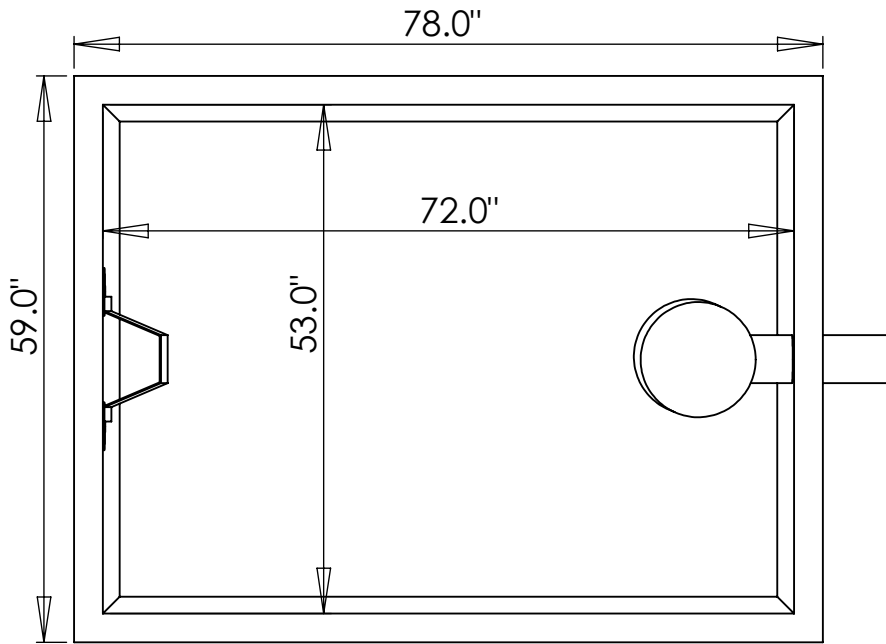

Optional 4" Inspection in lieu of Manhole

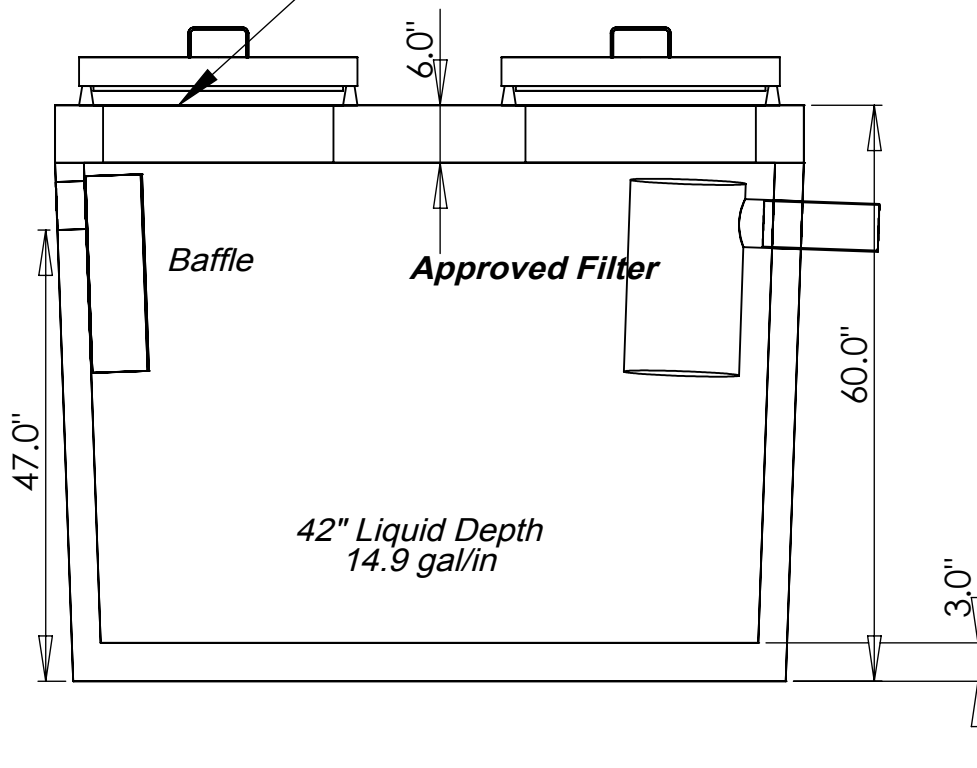

405 S. Arch St.
Janesville, WI 53548
(608)-752-6507

Toll Free: (888)-222-4541

www.dalmarayconcreteproducts.com
sales@dalmarayconcreteproducts.com